

# J1 JOEY TASK SUPPORT VEHICLE



A durable and dedicated multi-tasker, the **J1 Joey** from Blue Giant combines the abilities of an order picker, tugger, and elevating work platform. It is engineered and designed for locations where one vehicle is needed for a wide range of material handling functions.



**BLUE GIANT**®

# OVERVIEW + FEATURES



A

Electronic power steering with AC drive delivers intuitive and accurate maneuverability

B

Large 500 lb (227 kg) capacity front load tray

C

Low 9.5" (241 mm) step height allows for easy vehicle entry and exit

D

Exclusive 224AH AGM battery pack with 120v charger supports opportunity charging

E

One piece cover provides excellent maintenance access to all drive line components

F

Durable steel frame protects the hideaway rear tray and supports an I-beam channel mast for superior stability at height

**BLUE GIANT**®



LCD DASHBOARD WITH  
4 OPERATOR SPEED SETTINGS



FINGERTIP ERGONOMIC  
CONTROLS



LARGE HIGH VISIBILITY  
OPERATORS COMPARTMENT

## ALL-PURPOSE MATERIAL HANDLING.

Built to ANSI 92.6 standards, the J1 Joey provides an alternative to rolling ladders and larger order picking vehicles. The steel I-beam mast provides exceptional stability while elevated, and can be driven at height from one location to another. The J1 Joey can also carry a combined load of 1000 lb (363 kg) and turn in tight spaces, making it a highly productive asset for retail, warehousing, and distribution companies.

## DOUBLE YOUR PRODUCTIVITY.

The J1 Joey can do the work of different industrial truck types, and do it a lot faster. The high speed option enables it to operate at up to 5 mph when at ground level, while automatically reducing travel speed at height.

- Easy to maneuver, with precise electronic power steering and the ability to turn around in a 72" (1,829 mm) aisle
- Superior operator control
- Long duty cycle
- Supports quick battery changes

## DRIVE. TOW. ELEVATE.

When personnel need to work at height to complete a task, the J1 Joey is a rugged and reliable alternative to a rolling ladder. Compact and capable, the J1 Joey is highly maneuverable, intuitive in operation, and an excellent choice for facilities where general overhead maintenance, inventory, or order picking duties are routine.

## EXCLUSIVE TOWING OPTION.

The ability to drive, elevate and tow enables the J1 Joey to perform multiple functions. Facility fleet sizes can be reduced while keeping daily routines on time and consistent. The J1 Joey can tow up to 2,500 lb (1134 kg), providing rolling load support\* that can result in significant productivity gains and lower operating costs in all sorts of applications. No matter what the application—retail stores, production lines, parts facilities, or even general site maintenance—the J1 Joey delivers a unique value. (\*Use caution when selecting towables to avoid damage to equipment.)

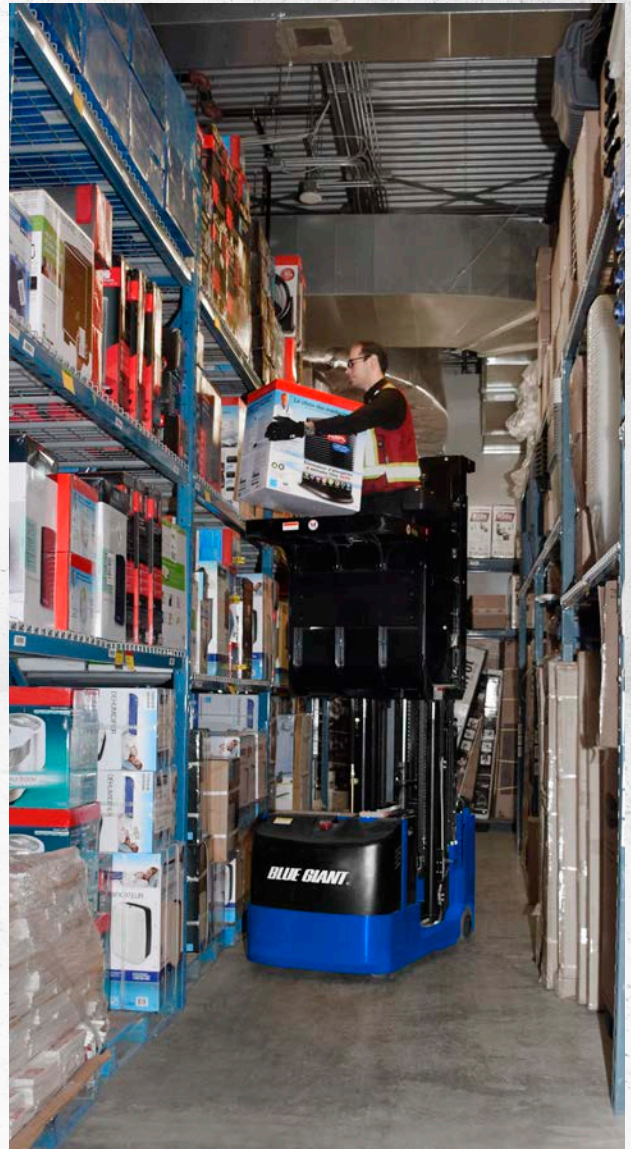

# SPECIFICATIONS + FEATURES

## CAPACITY

- 1,000 lb (454 kg) total vehicle capacity (derate applies above, 126" elevation)
- 300 lb (136 kg) operators compartment
- 500 lb (227 kg) front work platform
- 200 lbs (91 kg) rear "hide away" tray

## WHEELS / TIRES

- **DRIVE:** (1) 9" x 3" (229 mm x 176 mm) polyurethane
- **STABILITY:** (2) 3" x 2" (76 mm x 51 mm) polyurethane
- **LOAD:** (2) 8" x 3" polyurethane

## BATTERY COMPARTMENTS

- **J1-126 and J1-162 Compartment:** 29.1" x 7.9" x open Anderson 175 Gray - A-11
- **J1-192 Compartment:** 29.1" x 11" x open Anderson 175 Gray - A-11

## SPEED

- **TRAVEL:** Variable from 0 mph to 3.4 mph fully lowered (standard)
- Variable from 0 mph to 5.0 mph fully lowered (high speed option)
- Automatic speed reduction system when elevated
- 4 operator selectable speed settings
- **LIFT:** Up to 42fpm

## ELECTRICAL

- 24 volt ZAPI ACO travel and EPS ACO power steering controller with dash board display
- LCD dashboard displays hour meter, battery state of charge, travel speed, drive wheel direction, speed settings, and diagnostic codes

## MAST

- Heavy duty I-beam design provides excellent stability at height
- Steel mast channels and side mounted lift cylinders increases platform capacity

## CHASSIS

- Three point chassis design with along with 180° drive motor steering arc provides exceptional maneuverability.

## OPERATOR COMPARTMENT

- Ergonomic fingertip control for travel, lift, and lower functions provide the operator with logical intuitive drive characteristics while traveling at elevation or lowered
- Roomy operator compartment is designed for productivity
- Control pod guard rails fold down during operation and enclose the compartment

## REGENERATIVE BRAKES

- Regenerative braking is applied when the operator removes their hand from travel control or when travel speeds are reduced
- Electromagnetic parking brake is applied after the truck is stopped

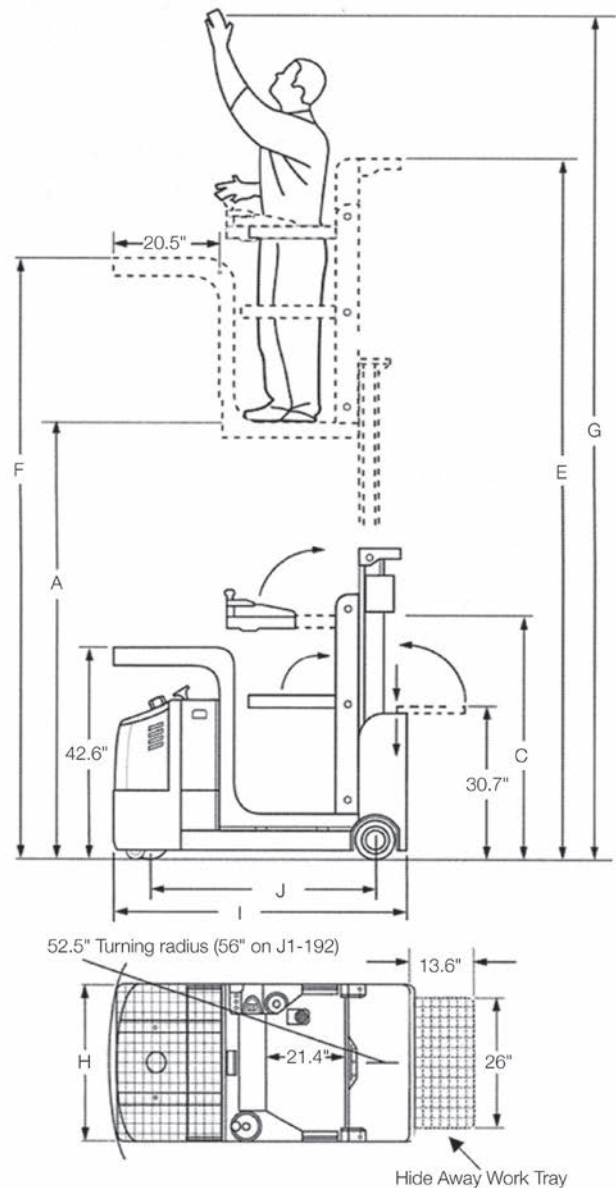

## STANDARD FEATURES

- Electronic power steering
- Large operator compartment with cushioned floor and backrest
- Hide away work tray
- Front and rear flashing lights
- Audible alarm when guardrail is raised
- One piece powerhead cover for easy service

MODEL #	MAST	LIFT HEIGHT	COL HEIGHT	EXTENDED HEIGHT	LOAD TRAY HEIGHT	WORKING HEIGHT	OVERALL WIDTH	OVERALL LENGTH	WHEEL BASE	WEIGHT (CHASSIS ONLY)
		A	C	E	F	G	H	I	J	
J1-126	Triple Stage	126" (3,200 mm)	62.6" (1,590 mm)	178.6" (4,536 mm)	159" (4,039 mm)	203" (5,156 mm)	31.5" (800 mm)	59.0" (1,499 mm)	45.2" (1,148 mm)	2,268 lb (1,029 kg)
J1-162	Triple Stage	162" (4,115 mm)	83.0" (2,108 mm)	235.0" (5,969 mm)	195" (4,953 mm)	239" (5,994 mm)	31.5" (800 mm)	59.0" (1,499 mm)	45.2" (1,148 mm)	2,610 lb (1,184 kg)
J1-192	Triple Stage	192" (4,877 mm)	83.0" (2,108 mm)	265.0" (6,731 mm)	225" (5,715 mm)	269" (6,832 mm)	34.0" (864 mm)	63.3" (1,608 mm)	49.0" (1,245 mm)	3,160 lb (1,433 kg)

**BLUE GIANT**  
BLUE GIANT EQUIPMENT CORPORATION

Corporate 410 Admiral Blvd  
Mississauga ON L5T 2N6  
t 905.457.3900 f 905.457.2313

USA 6350 Burnt Poplar Rd  
Greensboro, NC 27409  
[www.bluegiant.com](http://www.bluegiant.com)

AUTHORIZED DEALER

Blue Giant offers a full line of dock levelers, dock safety equipment, seals and shelters, accessories, ergonomic and scissor lift equipment and industrial trucks. Concurrent with our continuing product improvement program, specifications are subject to change without notice. Please contact Blue Giant for latest information. Some features illustrated may be optional in certain market areas.